



DECKING RISER PEDESTAL

Jouplast®

ADJUSTMENT IN HEIGHT FROM 50 TO 80 MM
«ESSENTIAL» RANGE



TECHNICAL DATA SHEET

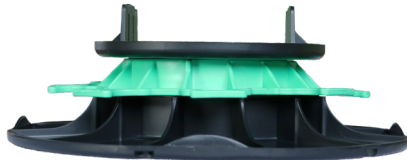

BENEFITS

- Quick and easy installation.
- Precise height adjustment using the rotating nut: no additional tools required.
- Base shape optimised: makes it easy to lay paving against a wall or in a corner.
- 2 vertical lugs: easier installation and allows the pedestal to be positioned on either side of the joist.

APPLICATIONS

- Ideal for creating natural wooden or composite decking for pedestrian use only.

RESISTANCE

- Resistance to crushing test exceeds 1T.

RECOMMENDATIONS

- For pedestrian use only.
- Outdoor use only.
- The sub frame must be constructed using wooden or metallic material only (not composite).
- When the riser pedestal is used at its highest position, we recommend adding a 10 mm extension to provide greater flexibility during adjustment.
- When the riser pedestal is used at its lowest position, we recommend using the rised pedestal of the next size down, adding a 10 mm extension for greater flexibility when adjusting.
- Decking riser pedestals should be used only on stabilised ground or on existing concrete support.
- For IFU, see the website.

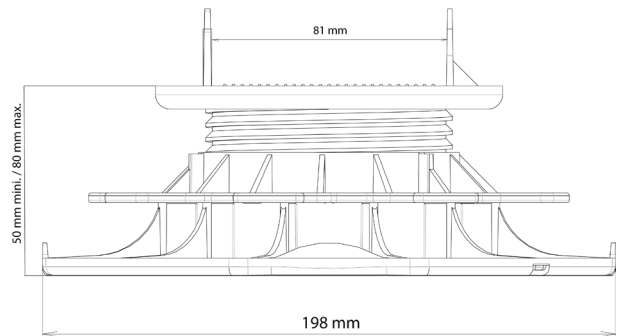

TECHNICAL DETAILS

- Material: recycled polypropylene
- Colour: black, green nut
- Adjustable height: mini.: 50 mm / maxi.: 80 mm
- Basis diameter: 198 mm / Bearing contact area: 300 cm²
- Support surface diameter: 120 mm / Bearing contact area: 100 cm²
- Vertical lug height: 18 mm
- Distance between lugs: 81 mm
- Weight: 257 g
- Resistance to temperature from -30°C to +60°C
- UV and frost resistant

PACKING

- Filled by 11 pieces (Pallet of 45 packs - Stackable pallet)

Document protected by copyright. Any reproduction, copy, extraction, reuse in others publications, translation or adaptation, display, distribution or modification, in whole or in part, without the written consent of TMP CONVERT is strictly prohibited and will be sanctioned. TMP CONVERT reserves the right to add, modify or delete information to any time without warning.



www.jouplast.com



FT_HL5080_2411_EN